

H59140

-UN-30JUL99



JOHN DEERE 914P' BELT PICKUP WITH PLATFORM

(SPECIFICATIONS AND DESIGN SUBJECT TO CHANGE WITHOUT NOTICE)

SERIAL NUMBER PLATE

USE ALL NUMBERS, LETTERS, AND SPACES SHOWN ON THE SERIAL NUMBER PLATE IN WARRANTY CORRESPONDENCE.

PICKUP PLATFORM (625001-)

ON THESE PLATFORMS, THE SERIAL NUMBER PLATE IS LOCATED ON THE LEFT-HAND SIDE OF THE FRAME.

EXAMPLE:
PICKUP PLATFORM

(FIRST LINE) H0 - FACTORY (HARVESTER WORKS)
 0912 - PLATFORM MODEL
 X - CONFIGURATION/MODEL SUFFIX
 625001 - PLATFORM SEQUENCE NUMBER (SERIAL NUMBER)
(SECOND LINE) PICKUP PLATFORM - PRODUCT TYPE

NOTE: BELT PICKUPS DO NOT HAVE SERIAL NUMBERS. CHANGES TO BELT PICKUPS ARE SHOWN BY YEARS.

IMPORTANT

THIS PARTS CATALOG CONTAINS COMPLETE PARTS INFORMATION ON THE THREE-ROLLER BELT AND PICKUP PLATFORM. IT IS IMPORTANT THAT THE CORRECT SERIAL NUMBER BE USED WHEN ORDERING PARTS.

SERIAL NUMBER LISTING INFORMATION

SERIAL NUMBER INFORMATION IS LISTED TO SHOW ON WHICH MACHINES EACH PART CAN BE USED, FOR EXAMPLE:

- THE PART CAN BE USED ON ALL MACHINES.
000000- THE PART CAN BE USED ON ALL MACHINES BEGINNING WITH THE SERIAL NUMBER LISTED.
-000000 THE PART CAN BE USED ON ALL MACHINES UP TO AND INCLUDING THE SERIAL NUMBER LISTED.
000000-000000 THE PART CAN BE USED ON ALL MACHINES BETWEEN AND INCLUDING THE SERIAL NUMBERS LISTED.

WHEN XXXXXX'S ARE LISTED IN PLACE OF A SERIAL NUMBER, A SERIAL NUMBER CHANGE WAS MADE BUT THE EXACT SERIAL NUMBER WAS NOT AVAILABLE WHEN THE CATALOG WAS PRODUCED.

*COPYRIGHT (C) 2000. DEERE & COMPANY. MOLINE, ILLINOIS
ALL RIGHTS RESERVED*

DIRECTION ARROW

ARROWS ARE USED WITH ILLUSTRATIONS TO INDICATE THE FRONT OF THE UNIT. "RIGHT-HAND" AND "LEFT-HAND" SIDES ARE DETERMINED BY FACING IN THE DIRECTION OF MACHINE FORWARD TRAVEL.

BOX-ENCLOSED ILLUSTRATIONS

A KEY NUMBER, SHOWN IN THE PARTS LIST, IS ASSIGNED TO A BOX ENCLOSING ALL PARTS SOLD AS A SERVICE ASSEMBLY. A BOX NOT KEYED INCLUDES NON-CURRENT PARTS.

KITS

KIT INFORMATION CAN BE FOUND IMMEDIATELY AFTER THE STORY IN WHICH IT IS USED. THE ILLUSTRATION IS REPEATED WITH ONLY THE KIT PARTS CALLED OUT AND WITH ALL OTHER PARTS SHOWN IN PHANTOM.

JDM REMANUFACTURED COMPONENTS

THE SERVICE PARTS LISTED IN THIS CATALOG ARE INTENDED FOR THE REPAIR OF ORIGINAL EQUIPMENT COMPONENTS. ALTHOUGH MOST SERVICE PARTS MAY BE USED TO REPAIR REMANUFACTURED COMPONENTS, THE REMANUFACTURED DESIGN MAY CHANGE PARTS SUFFICIENTLY SO THAT SERVICE PARTS ARE INADEQUATE OR NOT USABLE.

BOLT AND CAP SCREW STRENGTH IDENTIFICATION

BOLTS AND CAP SCREWS REQUIRED TO HAVE HIGH-STRENGTH QUALITIES EQUIVALENT TO SAE GRADE 8 ARE IDENTIFIED THROUGHOUT THIS CATALOG BY THE DESCRIPTION HS SAE 8. ALL STANDARD BOLTS AND CAP SCREWS ARE SAE GRADE 5 OR LOWER. BOLTS AND CAP SCREWS REQUIRED TO HAVE HIGH-STRENGTH QUALITIES EQUIVALENT TO PROPERTY CLASS 10.9 ARE IDENTIFIED THROUGHOUT THIS CATALOG BY THE DESCRIPTION HS 10.9. ALL STANDARD BOLTS AND CAP SCREWS ARE PROPERTY CLASS 8.8 OR LOWER.

SI UNITS OF MEASURE

METRIC DIMENSIONS ARE GIVEN, WHERE APPLICABLE, THROUGHOUT THIS PARTS CATALOG.

TRADEMARKS

THROUGHOUT THIS PARTS CATALOG, YOU WILL FIND THE FOLLOWING DEERE & COMPANY TRADEMARKS:

DIAL-A-SPEED™
DIAL-A-MATIC™
HARVESTRAK™

POSI-TORQ™
TORQ-GARD SUPREME®
QUIK-TATCH™

CHANGE INDICATOR LINE

CHANGES AFFECTING THE ORDERING OF PARTS ARE IDENTIFIED BY VERTICAL LINES MARKED IN THE L. H. MARGIN OF REVISED PARTS LISTING IMAGES. A LINE IS ALSO AT THE LEFT-HAND EDGE OF THE SAME PART NUMBER IN THE NUMERICAL INDEX TO SHOW THE LOCATION OF REVISED INFORMATION.

COMPLETE GOODS LISTINGS

COMPLETE GOODS ARE IN BOLD FACE TYPE. ORDER SEPARATELY. DO NOT INCLUDE ON REPLACEMENT PARTS ORDER.

SECTION INDEX

SECTION 05 - GENERAL INFORMATION

SECTION 10 - ROLLERS AND SUPPORTS

SECTION 15 - FRAME, STRIPPERS, DIVIDERS AND PLATES

SECTION 20 - HEADER HEIGHT CONTROL

SECTION 25 - AUGER AND DRIVE

SECTION 30 - HYDRAULICS

SECTION 35 - IDLERS, TIGHTENERS AND SHIELDS

SECTION 40 - BELTS, CHAINS, SHEAVES, SPROCKETS AND DECALS

SECTION 45 - NUMERICAL INDEX

**Thanks very much for your reading,
Want to get more information,
Please click here, Then get the complete
manual**

JustClickHere 

NOTE:

**If there is no response to click on the link above,
please download the PDF document first, and then
click on it.**

**Have any questions please write to me:
admin@servicemanualperfect.com**

ALPHABETICAL INDEX

GRID		PAGE	GRID		PAGE
A			E		
B17	ADAPTOR, BACK SHAFT - NEW HEADS TO OLD LEVEL LAND COMBINES.....	25 - 10	B8	EXTENSIONS, FLIGHT, AUGER	25 - 1
A23	ADAPTOR, DIAL-A-MATIC (CONVERSION TO 16- PIN CONNECTOR)	20 - 2	F		
A10	ARMS, FINGER HOLD-DOWN	10 - 2	B13	FINGERS, AUGER.....	25 - 6
B10	AUGER ADJUSTMENT BRACKETS.....	25 - 3	A10	FINGERS, HOLD-DOWN.....	10 - 2
B11	AUGER AND SHAFT.....	25 - 4	A15	FLAP, STRIPPER (132" BELT PICKUP)	15 - 1
B13	AUGER BEARINGS.....	25 - 6	A16	FLAP, STRIPPER (154" BELT PICKUP)	15 - 2
B11	AUGER COVER.....	25 - 4	B8	FLIGHT, AUGER, EXTENSIONS	25 - 1
B13	AUGER CRANK.....	25 - 6	B9	FLIGHT, WINDROW SPREADER	25 - 2
B13	AUGER FINGERS	25 - 6	A12	FRAME, IDLER ROLLERS	10 - 4
B8	AUGER FLIGHT EXTENSIONS	25 - 1	A18	FRAME, MAIN AND RUNNERS	15 - 4
B11	AUGER HUB	25 - 4	G		
B13	AUGER SHAFTS	25 - 6	A9	GAUGE WHEELS	10 - 1
B3	AUTO BELT SPEED	20 - 6	A20	GRAIN SLIDE.....	15 - 6
A22	AUTOMATIC HEIGHT CONTROL SENSOR, LINKAGE AND HANGER.....	20 - 1	B9	GUSSETT, WINDROW SPREADER.....	25 - 2
B			H		
B17	BACK SHAFT ADAPTOR - NEW HEADS TO OLD LEVEL LAND COMBINES.....	25 - 10	A22	HANGER, AUTOMATIC HEIGHT CONTROL.....	20 - 1
A20	BACK SHEETS	15 - 6	A24	HEADER HEIGHT CONTROL SHAFT, BEARINGS AND BRACKETS (685056-)	20 - 3
B15	BACKSHAFT	25 - 8	B1	HEADER HEIGHT CONTROL WIRING HARNESS	20 - 4
B13	BEARINGS, AUGER	25 - 6	A10	HOLD-DOWN FINGERS	10 - 2
A24	BEARINGS, HEADER HEIGHT CONTROL (685056-)	20 - 3	B22	HOSES, HYDRAULIC	30 - 2
A13	BEARINGS,CENTER AND IDLER ROLLERS DRIVE	10 - 5	A13	HOUSINGS, BEARINGS, IDLER DRIVE ROLLER.....	10 - 5
B3	BELT SPEED, AUTO.....	20 - 6	B11	HUB, AUGER	25 - 4
A17	BELTS AND FINGERS	15 - 3	B21	HYDRAULIC LINES AND BRACKET	30 - 1
A20	BOTTOM SHEET	15 - 6	B22	HYDRAULIC LINES AND HOSES	30 - 2
B21	BRACKET, HYDRAULIC LINES	30 - 1	B24	HYDRAULIC MOTOR COUPLER	30 - 4
B24	BRACKET, HYDRAULIC MOTOR.....	30 - 4	B24	HYDRAULIC MOTOR MOUNTING BRACKET.....	30 - 4
B10	BRACKETS, AUGER ADJUSTMENT	25 - 3	I		
A24	BRACKETS, HEADER HEIGHT CONTROL (685056-)	20 - 3	A12	IDLER ROLLERS.....	10 - 4
C			L		
B19	CABLE, STORAGE, POWER SHAFT.....	25 - 12	B5	LIGHTS, MARKER	20 - 8
A12	CENTER DRIVE.....	10 - 4	B6	LIGHTS, STUBBLE	20 - 9
C4	CHAIN, DRIVE, ON R.H. SIDE	40 - 1	B21	LINES, HYDRAULIC	30 - 1
B21	COUPLER, BRACKET, HYDRAULIC LINES	30 - 1	B22	LINES, HYDRAULIC	30 - 2
B24	COUPLER, HYDRAULIC MOTOR.....	30 - 4	A22	LINKAGE, AUTOMATIC HEIGHT CONTROL.....	20 - 1
B11	COVER, AUGER	25 - 4	M		
B13	CRANK, AUGER	25 - 6	B18	MAIN DRIVE SHAFT	25 - 11
D			A18	MAIN FRAME AND RUNNERS.....	15 - 4
C5	DECALS (685151-)	40 - 2	B5	MARKER LIGHTS	20 - 8
A23	DIAL-A-MATIC SENSING BOX (FOR CONVERSION TO 16-PIN CONNECTOR)	20 - 2	B24	MOTOR, COUPLER.....	30 - 4
B1	DIAL-A-MATIC WIRING HARNESS	20 - 4	B24	MOTOR, MOUNTING BRACKET	30 - 4
B1	DIAL-A-MATIC, HEADER HEIGHT CONTROL.....	20 - 4	B23	MOTOR, REEL (EATON).....	30 - 3
B1	DIAL-A-SPEED CONTROL	20 - 4	A23	MOUNTING, SENSING BOX, DIAL-A-MATIC (FOR CONVERSION TO 16-PIN CONNECTOR).....	20 - 2
C4	DRIVE CHAIN ON RIGHT-HAND SIDE	40 - 1			
B18	DRIVE SHAFT, MAIN	25 - 11			
A12	DRIVE, CENTER	10 - 4			

ALPHABETICAL INDEX - CONTINUED

GRID		PAGE	GRID	PAGE
P				
B22	PICKUP DRIVE	30 - 2		
A11	PICKUP SHIELDS	10 - 3		
B19	POWER SHAFT STORAGE CABLE ASSEMBLY	25 - 12		
R				
B23	REEL MOTOR (EATON)	30 - 3		
A10	RETAINER, HOLD-DOWN FINGERS	10 - 2		
A12	ROLLERS, IDLER	10 - 4		
A18	RUNNERS AND MAIN FRAME.....	15 - 4		
S				
A23	SENSING BOX, DIAL-A-MATIC (CONVERSION TO 16-PIN CONNECTOR)	20 - 2		
A22	SENSOR, AUTOMATIC HEIGHT CONTROL	20 - 1		
B11	SHAFT AND AUGER.....	25 - 4		
A24	SHAFT, HEADER HEIGHT CONTROL (685056-)	20 - 3		
B18	SHAFT, MAIN DRIVE	25 - 11		
B13	SHAFTS, AUGER.....	25 - 6		
A20	SHEET, BOTTOM	15 - 6		
A20	SHEETS, BACK	15 - 6		
C2	SHIELD.....	35 - 1		
A11	SHIELDS, PICKUP.....	10 - 3		
B3	SPEED, AUTO BELT.....	20 - 6		
C4	SPROCKETS AND TIGHTENERS ON R.H. SIDE	40 - 1		
A13	SPROCKETS,CENTER AND IDLER ROLLERS DRIVE	10 - 5		
B19	STORAGE CABLE, POWER SHAFT	25 - 12		
A20	STRIPPER	15 - 6		
A15	STRIPPER (132" BELT PICKUP)	15 - 1		
A16	STRIPPER (154" BELT PICKUP)	15 - 2		
A15	STRIPPER FLAP (132" BELT PICKUP)	15 - 1		
A16	STRIPPER FLAP (154" BELT PICKUP)	15 - 2		
B6	STUBBLE LIGHTS	20 - 9		
A9	SUPPORT, YOKE	10 - 1		
A18	SUPPORTS, MAIN FRAME.....	15 - 4		
T				
C4	TIGHTENERS AND SPROCKETS ON R.H. SIDE.....	40 - 1		
W				
A9	WHEEL YOKE	10 - 1		
A9	WHEELS, GAUGE	10 - 1		
B9	WINDROW SPREADER FLIGHT	25 - 2		
A23	WIRING HARNESS, ADAPTOR, DIAL-A-MATIC (F OR CONVERSION TO 16-PIN CONNECTOR)	20 - 2		
B1	WIRING HARNESS, HEADER HEIGHT CONTROL	20 - 4		
Y				
A9	YOKE SUPPORT	10 - 1		

A9

ROLLERS AND SUPPORTS

GAUGE WHEELS
(R.H. ILLUSTRATED)
 HP8832 -UN-22JUL99

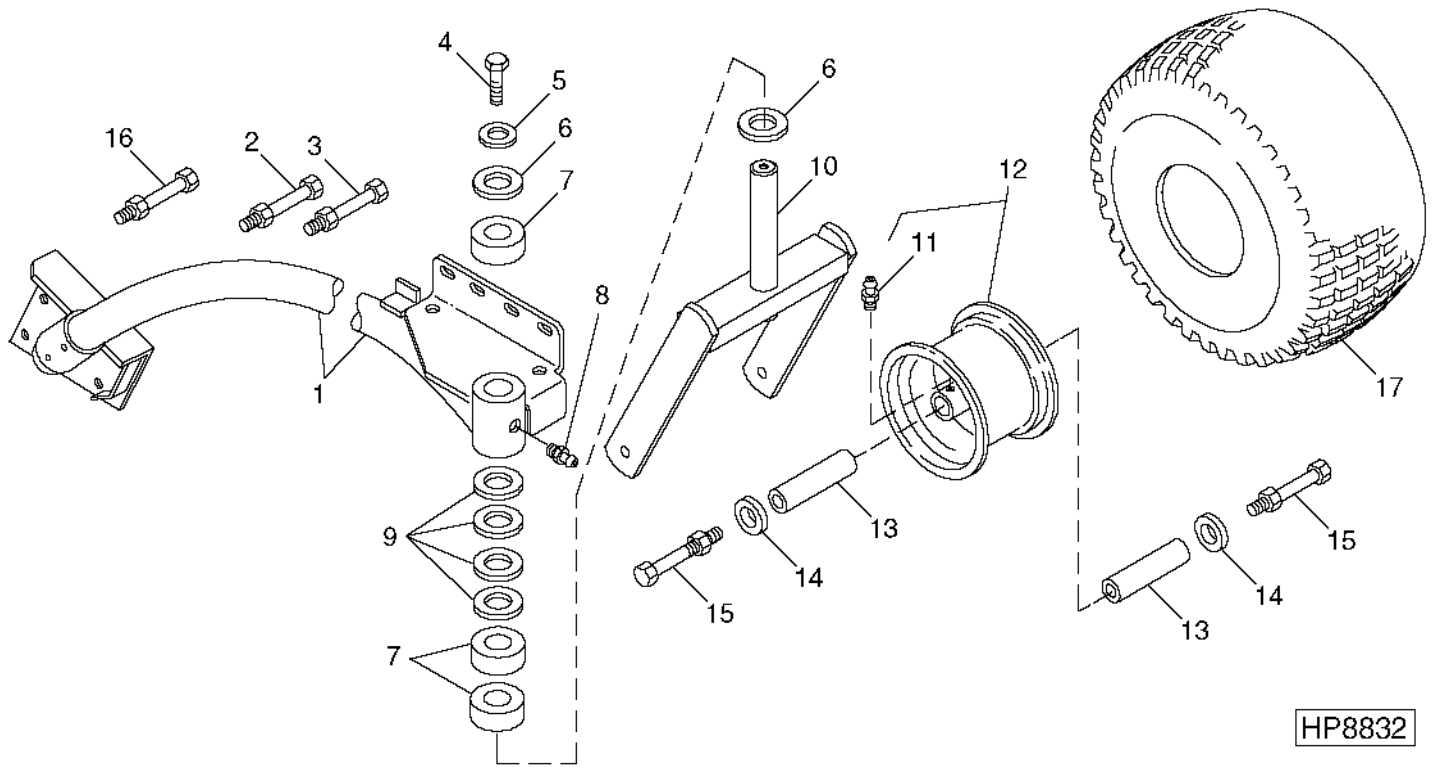

KEY	PART NO.	PART NAME	QTY	SERIAL NO.	REMARKS
1	AH132562	SUPPORT	1	R.H.	
	AH132563	SUPPORT	1	L.H.	
2	03M7200	BOLT	8	M12 X 40	
	14M7299	FLANGE NUT	8	M12	
3	03M7185	BOLT	4	M8 X 25	
	14M7298	FLANGE NUT	4	M8	
4	19M7788	SCREW	2	M12 X 25	
5	24H1347	WASHER	2	17/32" X 2" X 0.194"	
6	24H1520	WASHER	4	1-15/32" X 2" X 0.105"	
7	H111742	SLEEVE	6		
8	JD7797	LUBRICATION FITTING	2	STRAIGHT, 1/4"	
9	E32172	WASHER	8		
10	AH133711	YOKE	2		
11	JD7829	LUBRICATION FITTING	2	STRAIGHT, 5/16"	
12	AH133712	WHEEL	2	(USE 20 X 10.00 - 8 TIRES)	
13	H139004	PIN	2		
14	G6891E	CAP	4		
15	19M7843	SCREW	2	M16 X 35	
16	03M7197	BOLT	1	M12 X 25	
	14M7299	FLANGE NUT	1	M12	
17	TIRE	2	(4 PLY TIRE)	
	TIRE	2	(6 PLY TIRE)	

A10

HOLD-DOWN FINGERS AND SUPPORTS
HP5560 -UN-01JAN94

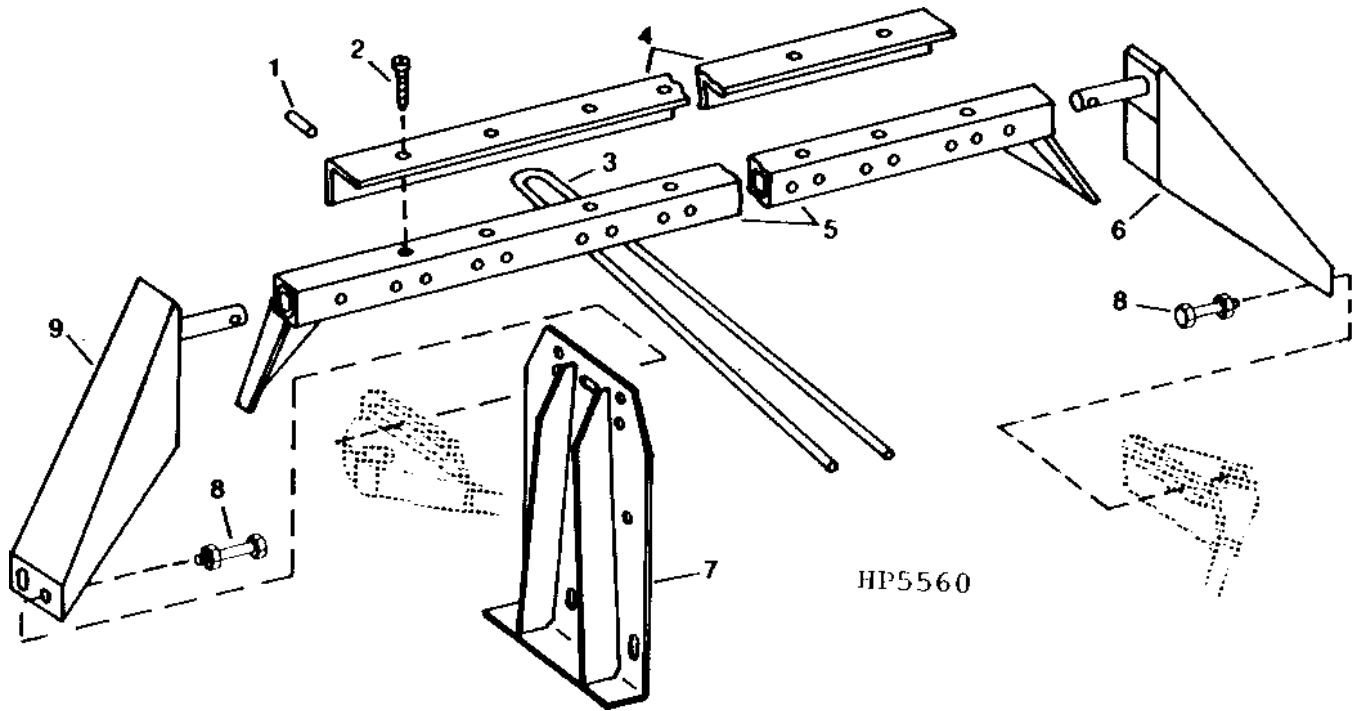

KEY	PART NO.	PART NAME	QTY	SERIAL NO.	REMARKS
1	34H105	SPRING PIN	2		1/4" X 1-1/2"
2	37M7083	SCREW	AR		M8 X 12 (132", 9 USED; 154", 10 USED)
3	H87747	FINGER	AR		(132", 31 USED; 154", 36 USED)
4	H106260	RETAINER	1		(132")
	H106259	RETAINER	1		(154")
5	AH98138	TUBE	1		(132")
	AH156408	TUBE	1		(154")
6	AH132570	SUPPORT	1		(R.H.)
7	AH132572	EXTENSION	2		L H OR R H, TWO REQUIRED
8	19M7789	SCREW	4		M12 X 30
	14M7299	FLANGE NUT	4		M12
9	AH132571	SUPPORT	1		(L.H.)
..	AH135954	EXTENSION	1		(INCLUDES AH132572, (4) 19M7789 AND (4) 14M7299)

A11

PICKUP SHIELDS
 HP5561 -UN-01JAN94

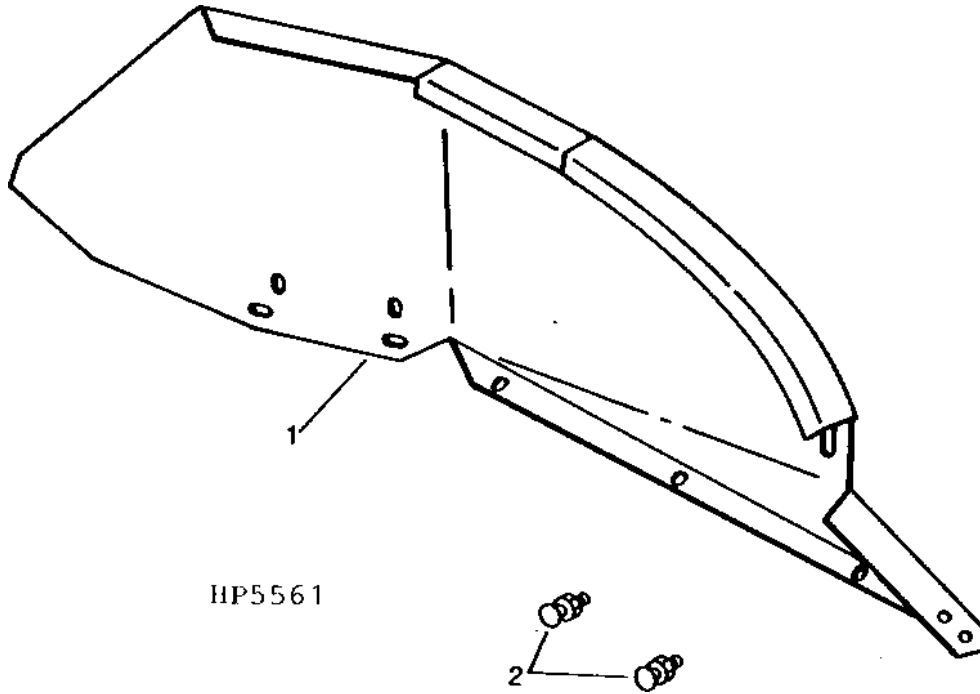

HP5561

KEY	PART NO.	PART NAME	QTY	SERIAL NO.	REMARKS
1	AH132566	WINDSHIELD	1	R.H.	
	AH132567	WINDSHIELD	1	L.H.	
2	19M7775	SCREW	12	M6 X 16	
	14M7397	LOCK NUT	12	M6	

A12

DRIVE, CENTER, AND IDLER ROLLERS
 HP5563 -UN-01JAN94

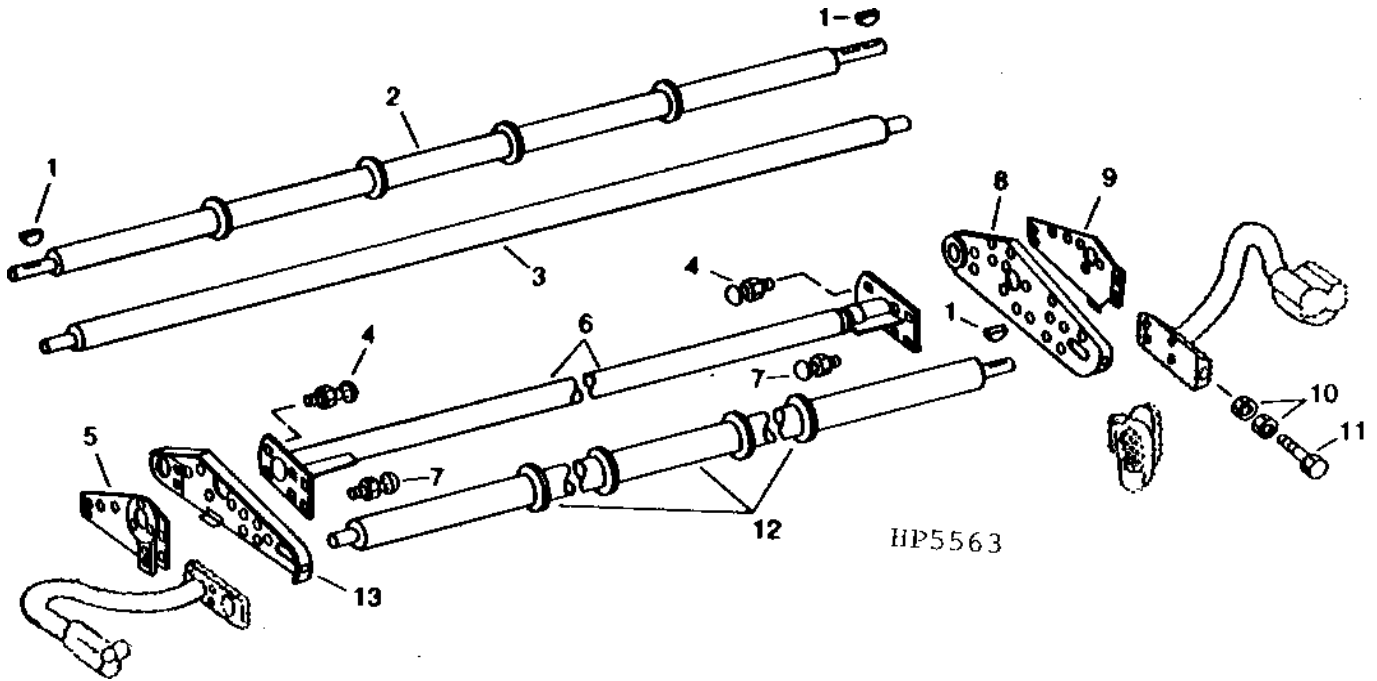

KEY	PART NO.	PART NAME	QTY	SERIAL NO.	REMARKS
1	26H40	SHAFT KEY	3	1/4" X 2-1/8"	
2	AH135591	ROLLER	1	(132")	
	AH135592	ROLLER	1	(154")	
3	AH111516	ROLLER	1	(132")	
	AH111515	ROLLER	1	(154")	
4	03M7186	BOLT	4	M8 X 30	
	14M7298	FLANGE NUT	4	M8	
5	AH165083	REINFORCEMENT	1		
6	AH129269	TUBE	1	(132")	
	AH129270	TUBE	1	(154")	
7	03M7200	BOLT	8	M12 X 40	
	14M7299	FLANGE NUT	8	M12	
8	AH165093	SHEET	1	L.H.	
9	AH165089	REINFORCEMENT	1	L.H.	
10	14H809	NUT	4	1/2"	
11	19H2062	CAP SCREW	2	1/2" X 4"	
12	AH135597	ROLLER	1	(132")	
	AH135598	ROLLER	1	(154")	
13	AH165082	SHEET	1	R.H.	

A13

ROLLERS AND SUPPORTS

SPROCKETS AND BEARINGS FOR DRIVE, CENTER, AND IDLER ROLLERS

HP8876 -UN-29JUL99

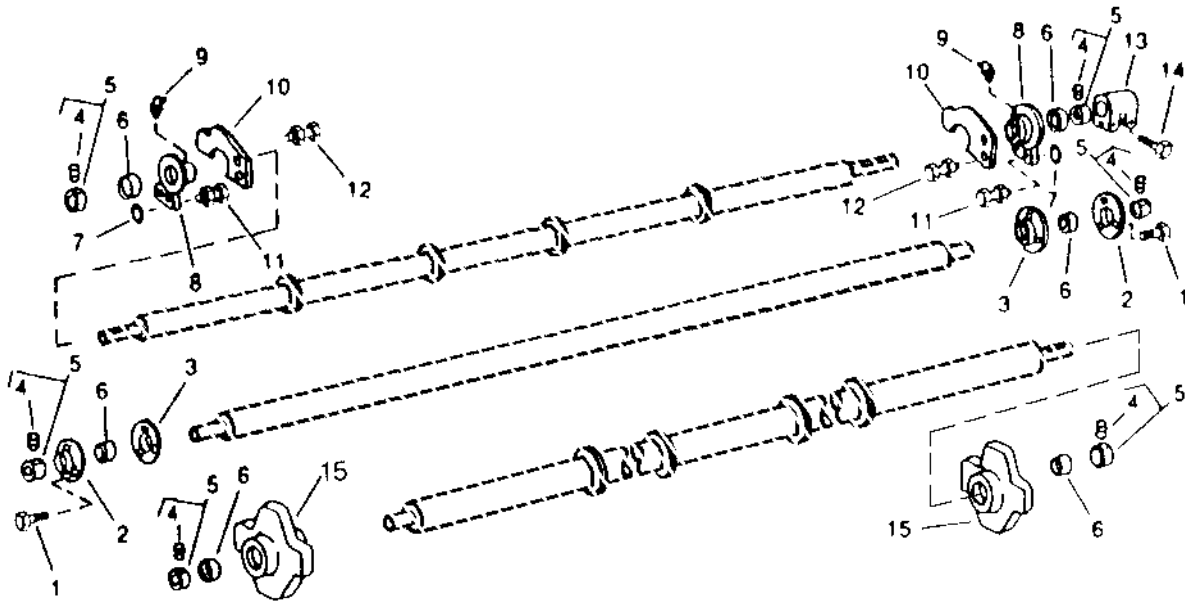

HP8876

KEY	PART NO.	PART NAME	QTY	SERIAL NO.	REMARKS
1	19M7784	SCREW	6	M10 X 20	
	12H304	LOCK WASHER	6	3/8"	
2	H135410	PRESSED FLANGED HOUSING	2		WITH GREASE FITTING
3	AH129420	PRESSED FLANGED HOUSING	2		
4	22H897	SET SCREW	6	1/4" X 1/4"	
5	JD8594	ECCENTRIC LOCKING COLLAR	6		
6	JD9397	BALL BEARING	6		
7	24H1219	WASHER	4	7/16" X 1" X 0.083" (132")	
	24H1341	WASHER	8	17/32" X 15/16" X 0.060", (154")	
8	H101594	HOUSING	2		
9	JD7788	LUBRICATION FITTING	2		
10	H118364	CLIP	2		
11	09H1611	BOLT	4	7/16" X 1-3/4" (132")	
	14H813	NUT	8	7/16" (132")	
	H168232	SCREW	4	(154")	
	14H809	NUT	8	1/2", (154")	
12	03M7196	BOLT	4	M10 X 50	
	14M7298	FLANGE NUT	4	M8	
13	H147690	COUPLING	1		
14	19H1765	CAP SCREW	2	3/8" X 1-3/4"	
	12H304	LOCK WASHER	2	3/8"	
15	H102699	HOUSING	2		

MEMORANDA

THIS PARTS LISTING IS CONTINUED

A15

FRAME, STRIPPERS, DIVIDERS AND PLATES

STRIPPER (132" BELT PICKUP)
HP5564 -UN-01JAN94

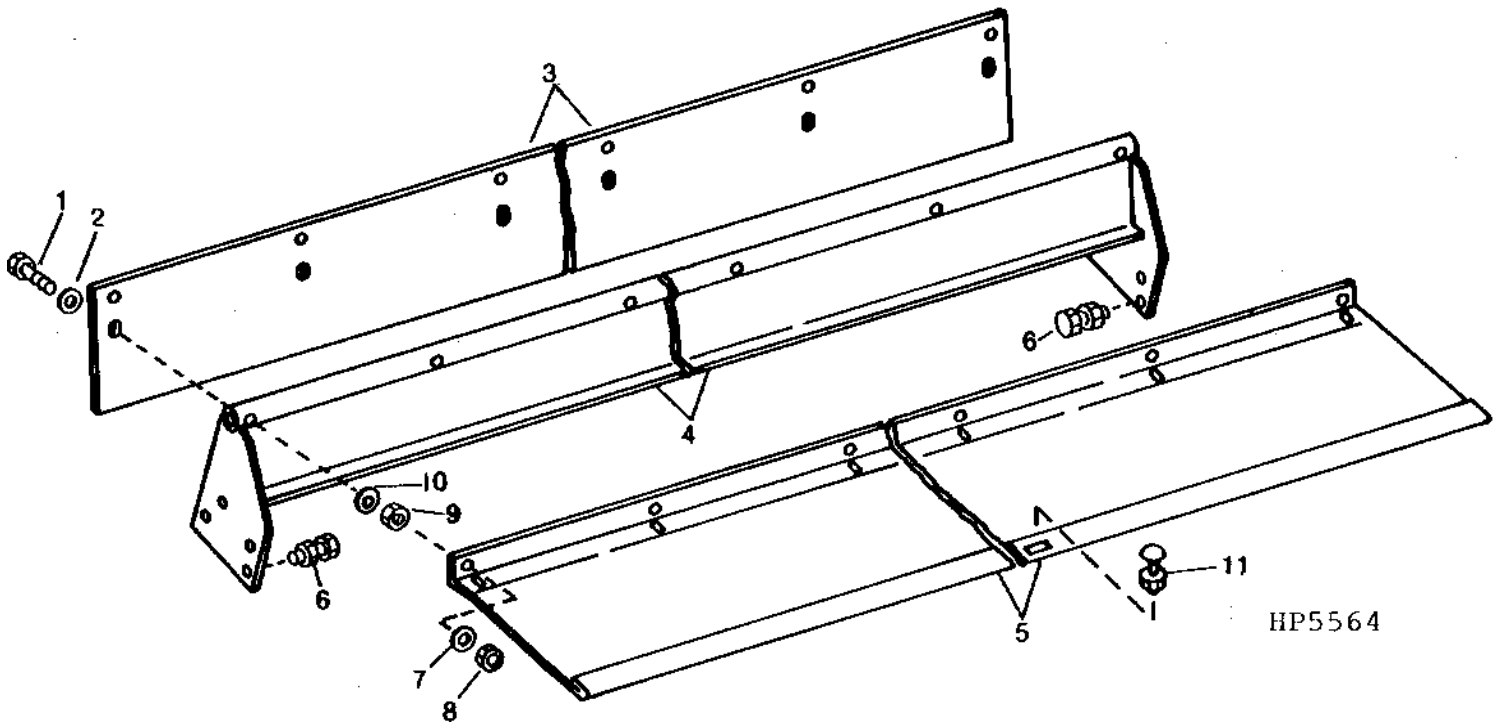

KEY	PART NO.	PART NAME	QTY	SERIAL NO.	REMARKS
1	19M8040	SCREW	AR	M6 X 60	
2	24H1288	WASHER	AR	9/32" X 1" X 1/16"	
3	H85488	FLAP	2	(132")	
4	AH108452	STRIPPER	1	(132")	
5	H137639	SUPPORT	2	(132")	
6	19M7785	SCREW	2	M10 X 25	
7	14M7296	FLANGE NUT	2	M10	
8	12H302	LOCK WASHER	AR	1/4"	
9	14M7397	LOCK NUT	AR	M6	
10	M80082	NUT	AR	6.350 MM (1/4")	
11	24H1287	WASHER	1	9/32" X 5/8" X 0.065"	
	03M7184	BOLT	1	M8 X 20	
	14M7298	FLANGE NUT	1	M8	

A16

FRAME, STRIPPERS, DIVIDERS AND PLATES

STRIPPER (154" BELT PICKUP)
HP5565 -UN-01JAN94

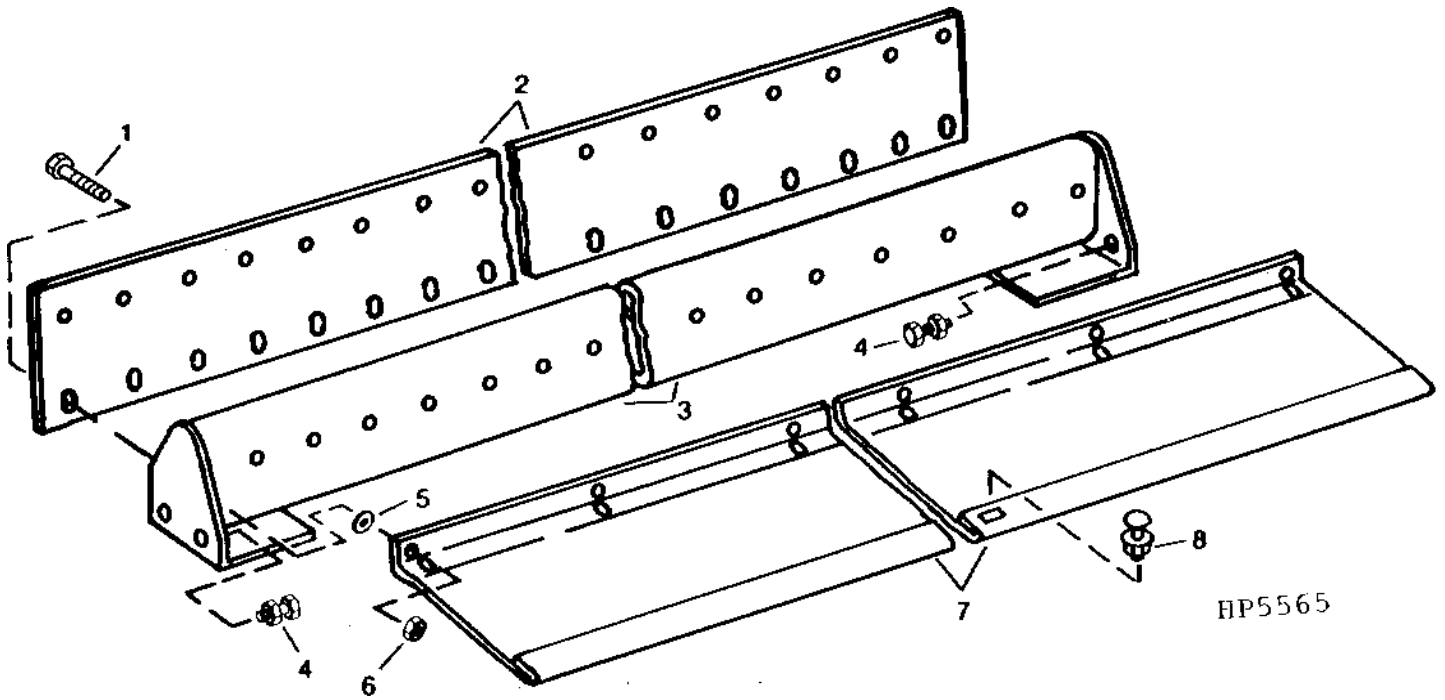

KEY	PART NO.	PART NAME	QTY	SERIAL NO.	REMARKS
1	19M8291	SCREW	15	M8 X 35	
2	H162036	FLAP	2		
3	AH133679	BAR	1		
4	19M7785	SCREW	2	M10 X 25	
	14M7296	FLANGE NUT	2	M10	
5	M84309	NUT	15		
6	14M7396	LOCK NUT	15	M8	
7	H138953	SUPPORT	1		
8	03M7184	BOLT	2	M8 X 20	
	14M7298	FLANGE NUT	2	M8	

A17

FRAME, STRIPPERS, DIVIDERS AND PLATES

BELTS AND PLASTIC FINGERS

HP869 -UN-01JAN94

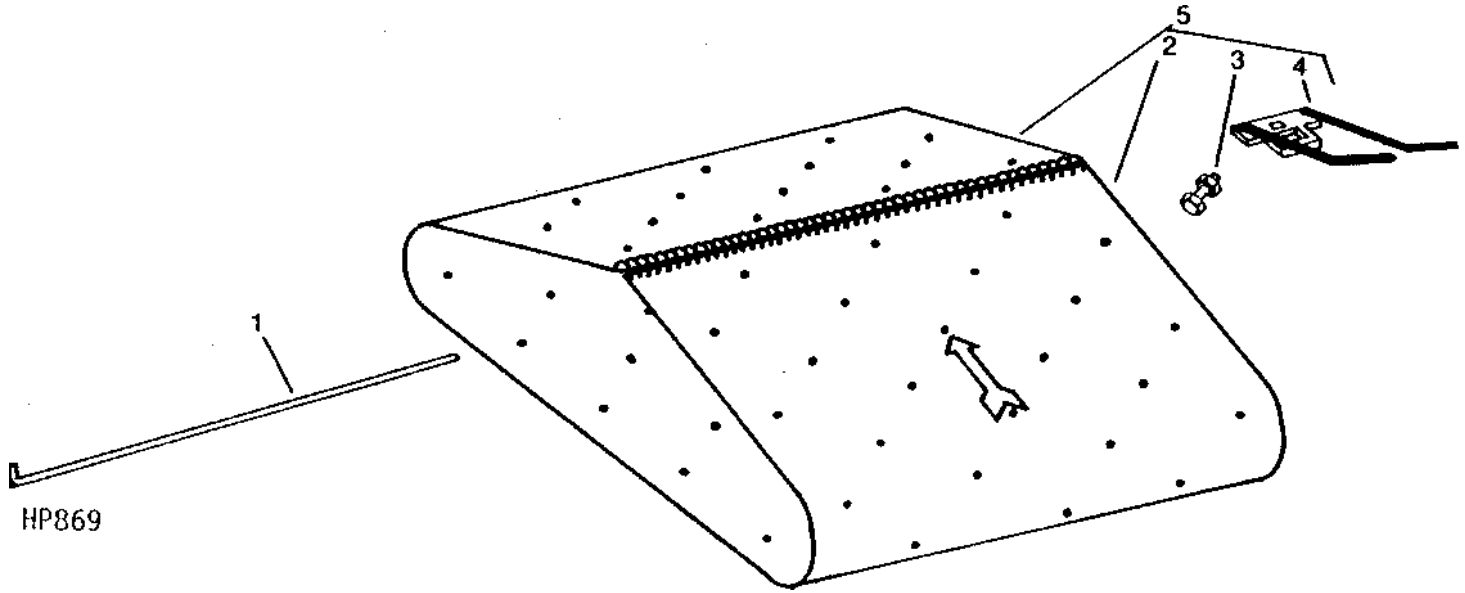

KEY	PART NO.	PART NAME	QTY	SERIAL NO.	REMARKS
1	H154675	PIN	AR		(132"-6 USED; 154" - 7 USED)
2	AH147908	BELT	AR		(132"-6 USED; 154"-7 USED)
3	AH86897	BOLT	AR		(132",-360 USED; AND 154",-420 USED) (10 PER CARTON)
4	H86248	FINGER	AR		(132"-360 USED; AND 154"-420 USED)
5	AH147909	BELT	AR		(132"- 6 USED; AND 154"-7 USED) (22" -7 - UKRAINE PLATFORMS ONLY)

A18

FRAME, STRIPPERS, DIVIDERS AND PLATES

FRAME AND RUNNERS
HP8833 -UN-22JUL99

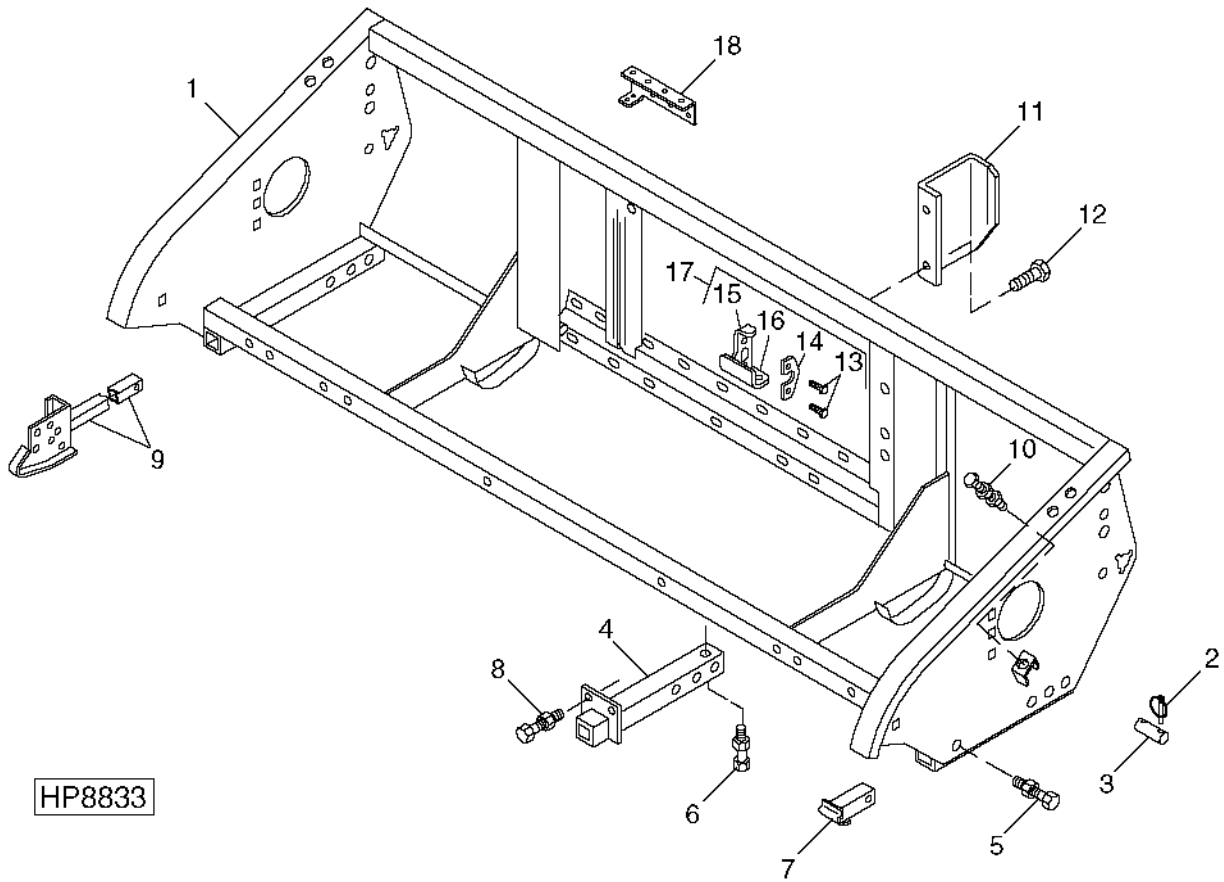

A19

FRAME, STRIPPERS, DIVIDERS AND PLATES

FRAME AND RUNNERS - CONTINUED

KEY	PART NO.	PART NAME	QTY	SERIAL NO.	REMARKS
1	AH162258	MAIN FRAME	1		
2	AA21292	QUICK LOCK PIN	4		
3	H148930	PIN	2		
4	AH143603	TUBE	2	(132")	
5	19M7820	SCREW	2	M12 X 100	
	14M7299	FLANGE NUT	2	M12 (132")	
6	19M7786	SCREW	2	M10 X 30	
	14M7276	NUT	2	M16	
7	AH89382	RUNNER	1	(132")	
8	19M7812	SCREW	4	M10 X 100	
	14M7296	FLANGE NUT	4	M10	
9	AH113221	SUPPORT	1	R.H. (132")	
	AH111174	SUPPORT	1	R.H. (154")	
	AH113222	SUPPORT	1	L.H. (132")	
	AH111175	SUPPORT	1	L.H. (154")	
10	A50325	SCREW	2	M16 X 80	
	14M7260	NUT	4	M16	
11	H112896	SHIELD	1		
12	37M7083	SCREW	2	M8 X 12	
13	19M7784	SCREW	4	M10 X 20	
14	H137143	PLATE	1		
15	REINFORCEMENT	1		
16	PLATE	1		
17	AH132905	PIN	1	R.H. (LATCH PIN ASSY)	
	AH132906	PIN	1	L.H. (LATCH PIN ASSY)	
18	H134219	STRIPPER	1	L H	
	H134218	STRIPPER	1	R H	

A20

FRAME, STRIPPERS, DIVIDERS AND PLATES

BACK SHEETS, BOTTOM SHEET, STRIPPER, AND GRAIN SLIDE

HP3587 -UN-01JAN94

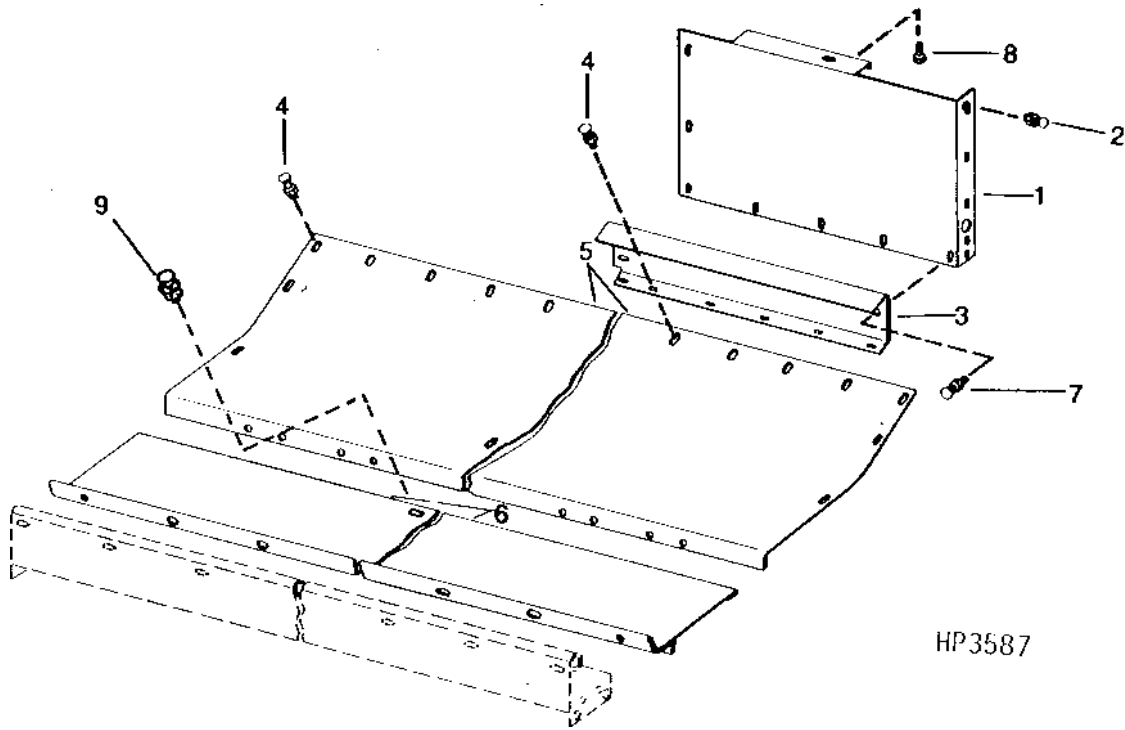

KEY	PART NO.	PART NAME	QTY	SERIAL NO.	REMARKS
1	H168829	SHEET	1	L.H.	
	H147574	SHEET	1	R.H.	
2	03M7184	BOLT	AR	M8 X 20	
	14M7298	FLANGE NUT	AR	M8	
3	H147575	SUPPORT	1	R.H.	
	H92692	STRIPPER	1	L.H.	
4	03M7190	BOLT	AR	M10 X 20	
	14M7296	FLANGE NUT	AR	M10	
5	H149471	SHEET	1		
6	H137639	SUPPORT	1	(132")	
7	03M7184	BOLT	AR	M8 X 20	
	14M7298	FLANGE NUT	AR	M8	
8	37H57	SCREW	2	5/16" X 3/4"	
9	03M7185	BOLT	1	M8 X 25	
	14M7298	FLANGE NUT	1	M8	

A22

HEADER HEIGHT CONTROL

AUTOMATIC HEIGHT CONTROL SENSOR, LINKAGE AND HANGER

(685056-)
 HP8864 -UN-30JUL99

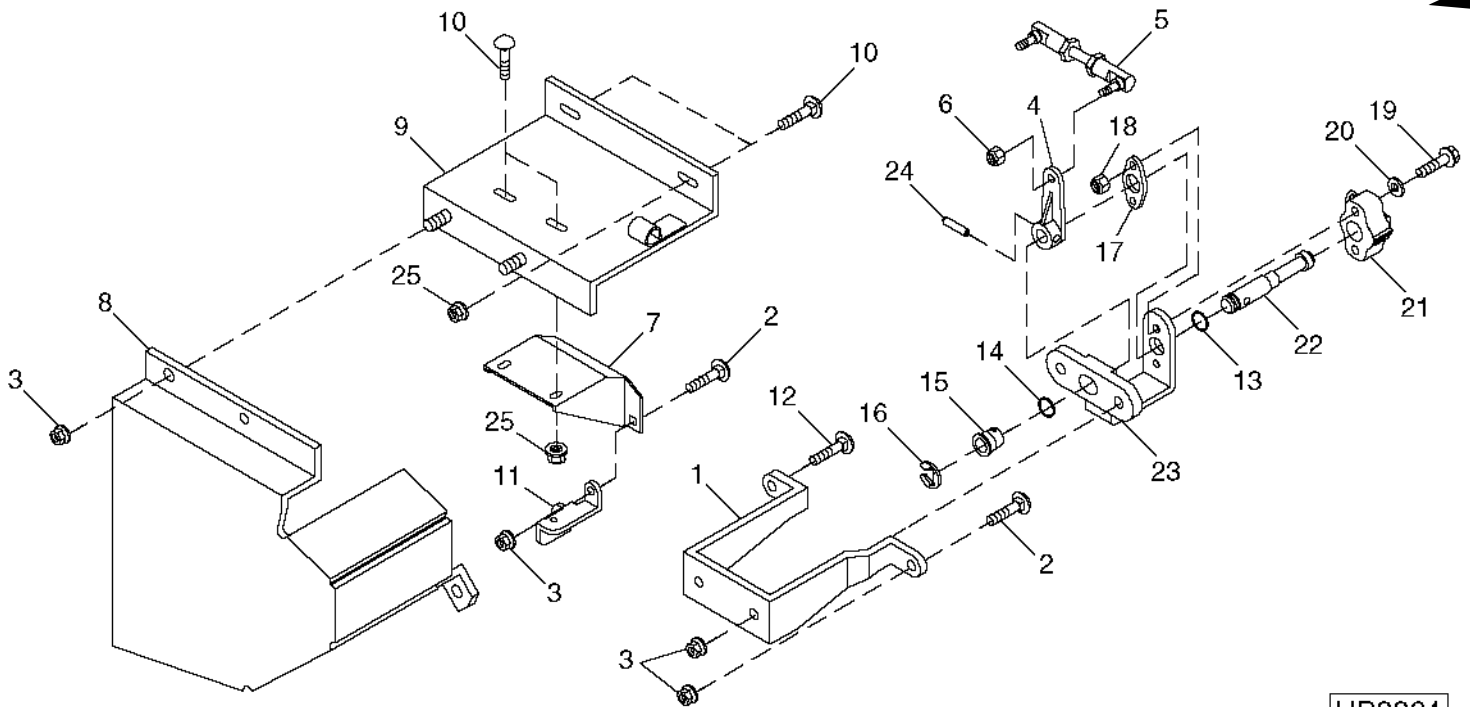

HP8864

KEY	PART NO.	PART NAME	QTY	SERIAL NO.	REMARKS
1	H163280	HANGER	1		
2	03M7184	BOLT	AR	M8 X 20	
3	14M7298	FLANGE NUT	AR	M8	
4	H166313	LEVER	1		
5	AH159809	LINKAGE	1		
6	14M7397	LOCK NUT	2	M6	
7	H76321	BRACKET	1		
8	H163282	SHIELD	1		
9	AH143755	SHIELD	1		
10	03M7221	BOLT	4	M6 X 16	
11	H163281	BRACKET	1		
12	03M7186	BOLT	1	M8 X 30	
13	R112679	SEAL	1		
14	P48347	O-RING	1		
15	R41076	GROMMET	1		
16	R26871	SNAP RING	1		
17	R86457	SUPPORT	1		
18	14M7297	NUT	2	M5	
19	21M7261	SCREW	2	M5 X 45	
20	12M7060	WASHER	2	5.300 MM	
21	RE69297	SENSOR	1		
22	R111692	SHAFT	1		
23	H156936	BRACKET	1		
24	34H305	SPRING PIN	1	7/32" X 2"	
25	14M7303	FLANGE NUT	4	M6	